

Image controlling method and device for carrying out the same.

Patent Number: EP0205726
Publication date: 1986-12-30
Inventor(s): NAKAMURA FUMIO
Applicant(s): HAL LAB INC (JP)
Requested Patent: EP0205726, A3, B1
Application Number: EP19860100265 19860110
Priority Number(s): JP19850123510 19850608
IPC Classification: H01H25/04
EC Classification: H01H25/04
Equivalents: DE3685690D, DE3685690T, JP61292734
Cited Documents: EP0024813; DE1268251; WO8403051; DE2810609

Abstract

An image controlling method and a device for carrying out the same, for shifting a processing position indicating point displayed on a CRT, for example, of a computerized game, in response to the variation of an image displayed on the CRT, by selectively closing one or two switches among a plurality of switches (3) disposed at equal angular intervals around and at the same distance from a fixed point corresponding to the center of a control disk (4). The control disk (4) is inclined in a desired direction by applying a light pressure with the hand to a generally spherical operating ball (7) which fits the palm of the hand snug so that the switch or switches corresponding to the desired direction are closed.

Data supplied from the esp@cenet database - I2

Description

IMAGE CONTROLLING METHOD AND DEVICE FOR CARRYING OUT THE SAME DESCRIPTION

The present invention relates to an image controlling method for shifting a processing position indicating point for instructing a processing position, in order to make a processing unit process an image displayed on the cathode ray tube (abbreviated to "CRT" hereinafter) of a computerized game or the like.

The keyboard system, the track ball system and the control lever system have been well-known means for shifting a processing position indicating point. The keyboard system needs to shift the processing position indicating point in two separate steps in both directions along the x-coordinate axis and the y-coordinate axis, and hence the processing position indicating point cannot be shifted quickly. Therefore, the keyboard system is incapable of dealing with a game in which an image varies rapidly on the CRT, and hence the keyboard system is employed rarely for image control. On the other hand, the track ball system and the control lever system are capable of composing the components of the x-coordinate axis and the y-coordinate axis and shifting the processing position indicating point quickly in the composite direction by a single action, hence, are capable of quick image control.

Thus the track ball system and the control lever system are deemed to be preferable for image control. However, since the device of the track ball system is complicated in mechanism and large in size, the device of the control lever system, which is simple and inexpensive, is employed more often.

Figs. 2 (a) and 2 (b) illustrate the mode of application and the basic construction of a conventional device of the control lever system, respectively.

In Fig. 2 (a), there are shown a control unit C', a processing unit MPU and a TV display unit D. An image is displayed on the CRT of the TV display unit D. Ordinarily the control unit C' is disposed near the operator for the remote control of the processing unit MPU. The control unit C' has a base B having a central protuberance and a lever L extending upward from the top surface tp of the central protuberance through a through hole h formed in the central portion of the central protuberance. The lever L is movable in the range defined by the through hole h.

Push-button pb provided on top of a grip G and on the upper surface of the base B are trigger buttons, for example, for launching a missile or the like.

The basic construction of the control unit C' is illustrated in Fig. 2 (b). Referring to Fig. 2 (b), the lever L is provided at the upper and lower ends thereof with the grip G and a pushing ball P, respectively, and is tiltable in all directions on an intermediate point 0 on the center axis thereof so that the grip G can be moved to an desired position within the range limited by a broken line R. Four switches S1 to S4 having contact terminals S1a and S1b, S2a and S2b, S3a and S3b, and S4a and S4b, respectively, are disposed on four sides of the pushing ball P. When the grip G is moved in a direction R1, the pushing ball P presses the flexible contact terminal S1a of the switch S1 against the rigid contact terminal S1b of the same. When the grip G is moved in a direction R2, the pushing ball P presses the flexible contact terminal S2a of the switch S2 against the rigid contact terminal S2b of the same. When the grip G is moved in a direction R3, for example, the pushing ball presses the respective flexible contact terminals S3a and S4a of the switches S3 and S4 against the respective rigid contact terminals S3b and S4b of the same, respectively. Thus the switches S1 to S4 are closed or opened selectively according to the position of the grip G. The processing position indicating point is moved in a direction corresponding to the closed switch or switches among the switches S1 to S4 by a distance corresponding to the duration of the closed state of the switch or switches.

In such a conventional control unit C' of the control lever system, the lever L is tilted by pulling or pushing the grip G so that the grip G is moved substantially within a plane parallel to the base surface of the base B.

Therefore, when the control unit C' is placed on a table, a force acts on the base B in the same direction as the tilting direction of the lever L, and thereby the base B tends to slide on the table. If the base B slips, the lever L is unable to be tilted to a desired extent, and hence the desired manipulation of the control unit C' is impossible.

In order to check the slip of the base B, a sucking disk or the like is attached to the backside of the base B. However, when the player is absorbed excessively in playing the game and is excited to apply an excessive force to the lever L, the conventional means for checking the slip of the base B, such as sucking disk, is incapable of preventing the slip of the base B. Thus, it has been desired to develop fundamental measures capable of preventing the slip of the base B.

The pushing ball P of the lever L and the flexible contact terminals S1a to S4a of the switches S1 to S4 are disposed with

gaps of a preselected width therebetween in order to prevent an erroneous operation and the distance between the intermediate point O of the lever L and the grip G is greater than the distance between the intermediate point O and the pushing ball P in order to form the control unit C' in a compact structure.

Therefore, the grip G of the lever L needs to be moved through a comparatively long distance to actuate the switches S1 to 84.

Moving the grip G requires the motion of the muscles of the arm and the shoulder. However, since the reaction of these muscles is comparatively slow, it is impossible to count on the quick action of the hand in moving the processing position indicating point quickly in response to the variation of the image, which is a disadvantage of the control lever system.

Furthermore, since the lever L is adapted basically for tilting in all directions, the lever L is likely to make a procession about the intermediate point O, when the grip G is pushed or pulled in one direction. Such a procession of the lever L causes an erroneous action of the switches, and hence desired manipulation of the control unit C' cannot be achieved.

In order to prevent the procession of the lever, a limiter, not shown, is provided within the base B, however, since the muscles of the arm and the shoulder tend to apply a large force to the lever L, limiter is worn rapidly reducing the life of the control unit C'.

The present invention has been made to solve the problems in the conventional image controlling method of the control lever system and the conventional device for carrying out the same. Accordingly, it is an object of the present invention to provide an image controlling method and a device for carrying out the same, employing inexpensive switches, having a simple construction, capable of quickly reacting to the variation of the image, capable of being manipulated by a light downward pressure applied thereto with the hand, having a control unit which will never slide on the table, and capable of obviating erroneous operation resulting from the procession of the control lever.

According to one aspect of the present invention, an image controlling method for shifting a processing position indicating point for instructing a processing unit of an image processing position on a CRT by closing one or two switches among at least four switches disposed at equal angular intervals around a preselected central point on a plane and at the same distance from the central point so that the processing position indicating point is shifted in a direction corresponding to the closed switch or switches for a period corresponding to the duration of the closing of the switch or switches, includes inclining a control plate, which is supported so as to be inclined in all directions on a swing shaft set up at the central point, in a desired direction to close the corresponding switch or switches.

Thus, the image controlling method according to the first aspect of the present invention employs switches as essential means, however, the image controlling method employs, instead of a control lever, a control plate supported on a swing shaft set up at a central point so as to be inclined in all directions, for controlling the switches.

According to the first aspect of the present invention, one or two desired switches among a plurality of switches disposed at equal angular intervals around a central point are closed by applying a light vertical pressure to the control plate supported on the swing shaft set up at the central point, to incline the control plate in a desired direction.

According to a second aspect of the present invention, an image controlling device for shifting a processing position indicating point for instructing a processing unit of an image processing position on a CRT by closing one or two switches among at least four switches disposed at equal angular intervals around and at the same distance from the central point on a plane so that the processing position indicating point is shifted in a direction corresponding to the closed switch or switches for a period corresponding to the duration of the closing of the switch or switches, comprises: a cylindrical base having an upper wall closing the upper end thereof; a bearing having a bowl-shaped recess formed in the upper end thereof and provided at the center of the upper wall of the cylindrical base; at least four switches having actuators extending upward from the bodies thereof, respectively, and disposed at equal intervals around and at the same distance from the bearing; a control disk having a pivot having a predetermined length and a semispherical tip capable of being fitted in the bowlshaped recess of the bearing, and formed so as to project from the backside of the control disk, and a contact ring, namely, a circular protuberance formed in the backside of the control disk with the center at the center of the bearing and having a preselected diameter; and a domed operating ball formed integrally with the control disk so as to cover the entire surface of the control disk and having a sleeve extending downward by a preselected length from the circumference of the control disk, wherein the control disk is disposed with the tip of said pivot received in the recess of said bearing, with the contact ring in light contact with the actuators of the switches and with the sleeve of the operating ball covering a predetermined upper portion of the base, the control disk is inclined on the bearing supporting the pivot in a direction corresponding to the direction of action of a pressure applied to the upper portion of the operating ball, and when the control disk is inclined, the contact ring depresses the actuator or actuators of the switch or switches against the resilient force of a spring or springs for normally opening the switch or switches according to the direction of inclination of the control disk.

The image controlling device according to the second aspect of the present invention enables inclining the control disk with the hand and surely transmits a vertical pressure applied to the operating ball to the switch or switches so that the switch or

switches are closed.

The above and other objects, features and advantages of the present invention will become more apparent from the following description of the preferred embodiments thereof taken in conjunction with the accompanying drawings

Fig. 1 (a) is a partially sectional front elevation of an essential portion of an image controlling device, in a preferred embodiment, according to the present invention;

Fig. 1 (b) is a fragmentary sectional view of Fig. 1 (a);

Fig. 1 (c) is a general perspective view of an image controlling device, in a preferred embodiment, according to the present invention;

Fig. 1 (d) is a partially sectional front elevation, similar to Fig. 1 (a), of assistance in explaining the operation of the image controlling device of Fig. 1 (c);

Fig. 2 (a) is a general perspective view of a computerized game apparatus employing a conventional image controlling device; and

Fig. 2 (b) is a perspective view showing the basic construction of the conventional image controlling device of Fig. 2 (a).

The present invention will be described hereinafter with reference to a preferred embodiment thereof illustrated in Figs. 1 (a) to 1 (d).

Referring to Fig. 1 (a) illustrating an essential portion of an image controlling device C of the present invention, there are shown a cylindrical base 1 having an upper wall closing the upper end thereof, a bearing 2 provided at the center of the upper wall of the cylindrical base 1, and four switches 3 (only two of them are illustrated in Fig. 1 (a)). A bowl-shaped recess is formed in the upper end of the bearing 2.

Each of the switches 3 comprises, as illustrated in

Fig. 1 (a) by way of example, contact terminals a and b, a coil spring s for normally opening the switch, a case 31 containing the contact terminals a and b and the coil spring s, and an actuator 32 for closing the switch, projecting from the upper surface of the case 31. The contact terminals a and b are connected to a processing unit MPU by conductors extended through the internal cavity of the cylindrical base 1. The four switches 3 are disposed on the upper wall of the cylindrical base 1 at equal angular intervals around and at the same distance from the center of the bearing 2.

The cylindrical base 1, the bearing 2 and the switches 3 constitute the lower structure of the image controlling device of the present invention.

The upper structure of the image controlling device of the present invention comprises a control disk 4, a pivot 5 provided at the center of the backside (underside) of the control disk 4, a contact ring 6, namely, a circular protuberance, formed in the backside of the control disk 4, and an operating ball 7 formed integrally with the control disk 4.

The pivot 5 has a preselected length and a preselected diameter. The tip of the pivot 5 is formed in a semispherical shape so that the tip of the pivot 5 can be fitted in the recess of the bearing 2.

The contact ring 6 is formed with the center at the center of the pivot 5 so as to correspond to the actuators 32 of the switches 3.

The operating ball 7 covers the upper surface of the control disk 4 entirely and has a sleeve 71 extending below the circumference of the control disk 4. The operating ball 7 is a domed member having a shape corresponding to a substantially three quarters of a sphere. Accordingly, the control disk 4 is observed through the bottom opening of the operating ball 7. The inside diameter of the bottom opening of the operating ball 7 is greater than the outside diameter of the cylindrical base 1 by a preselected value.

The semispherical tip of the pivot 5 is fitted in the recess of the bearing 2 to assemble the upper and lower structures.

The length of the pivot 5 and the height of the contact ring 6 are decided so that the contact ring 6 is practically in contact with the actuators 32 of the four switches 3, and the size of the operating ball 7 is decided so that the sleeve 71 of the operating ball 7 covers a preselected upper portion of the cylindrical base 1, when the upper and lower structures are assembled.

Furthermore, the respective dimensions of the components are decided so that the operating ball 7 is received snug in the palm of the hand.

Fig. 1 (c) illustrates the general configuration of the image controlling device of the present invention. The cylindrical base 1 is fixed to a box 8. A plurality of push-buttons pb, for example, push-buttons for launching missiles or the like, are provided in an outside extension of the box 8.

The manner of operation of the image controlling device C of the present invention will be described hereinafter. The

operating ball 7 of the image controlling device C placed on a table is received in the palm of the hand. When the control disk 4 is required to be inclined toward the right or toward the left, the wrist is twisted slightly toward the little finger or toward the thumb, respectively; when the control disk 4 is required to be inclined toward this side or toward the opposite side, the wrist is bent up or bent down, respectively; and when the control disk 4 is required to be inclined toward an intermediate side between the right-hand side and this side or the opposite side or between the left-hand side and this side or the opposite side, the operating ball 7 is moved through the combination of a twisting motion and a bending motion of the wrist accordingly. When a pressure is thus applied to the operating ball 7, the pivot 5 of the control disk 4 is tilted on the tip in the bearing 3 accordingly, for example, as illustrated in Fig. 1 (d).

Consequently, the control disk 4 is inclined according to the acting direction of the pressure applied to the operating ball 7, and thereby the contact ring 6 which has been in light contact with the actuators 32 of the switches 3 presses the actuator or actuators 32 of the corresponding switch or switches 3. The actuator or actuators 32 thus pressed are depressed against the resilient force of the spring or springs s to bring the contact terminal or contact terminals a into contact with the contact terminal or contact terminals b of the switch or switches 3.

When the pressure applied to the operating ball 7 with the palm 10 removed, the contact terminal a which has been in contact with the contact terminal b is moved away from the contact terminal b and the corresponding actuator 32 is raised by the spring s, so that the operating ball 7 is returned to a position illustrated in Fig. 1 (a).

Naturally, in a modification, six switches 3 may be disposed at angular intervals each of 60 or eight switches 3 may be disposed at angular intervals each of 45

Furthermore, although the contact terminals a and b, and the spring s normally opening the switch 3 are contained in the case 31, the case 31 may be used merely as a stopper, the stem of the actuator 32 may be extended through the stopper 31 and a hole formed in the upper wall of the cylindrical base 1 into the internal cavity of the cylindrical base 1, and the contact terminals a and b and the spring s may be disposed within the internal cavity of the cylindrical base 1.

Still further, the control disk 4, the pivot 5 and the operating ball 7 are formed in an integral member in this embodiment, however, those components may be formed either by molding a synthetic resin in an integral member or by mechanically or adhesively joining those components individually formed of synthetic resins or other suitable materials, respectively. Thus the process for forming those components is entirely optional.

As apparent from the foregoing description of the preferred embodiment of the present invention, the image controlling device of the present invention enables quick response to the variation of an image merely through the application of a light pressure to the operating ball with the hand, and hence the slip and the undesirable movement of the image controlling device on the table will never occur. Accordingly, the correct controlling operation is ensured and the operator is less fatigued. Furthermore, since only a vertical pressure is applied to the operating ball of the image controlling device, while any lateral pressure or rotative pressure is not applied to the operating ball, the image controlling device is less subject to damage, hence, the life of the image controlling device is extended. Still further, since the image controlling device of the present invention employs inexpensive switches and has a simple construction, the image controlling device of the present invention can be manufactured at a reduced manufacturing cost.

Although the invention has been described in its preferred form with a certain degree of particularity, it is to be understood that many variations and changes in the invention are possible without departing from the scope and spirit thereof.

The features disclosed in the foregoing description, in the following claims and/or in the accompanying drawings may, both separately and in any combination thereof, be material for realizing the invention in diverse forms thereof.

Data supplied from the esp@cenet database - I2

1/3

FIG. 1 a

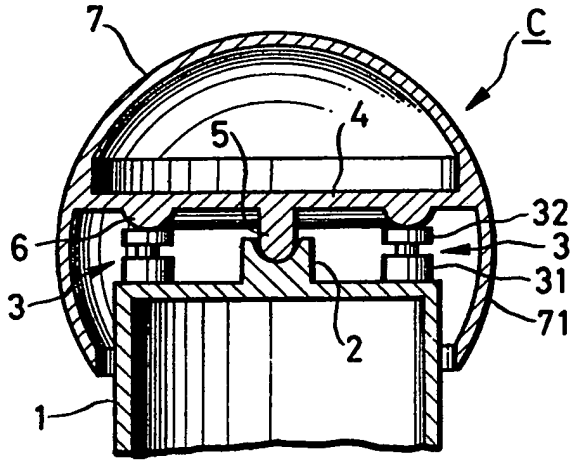

FIG. 1 b

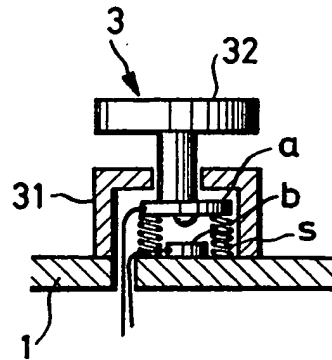

FIG. 1 d

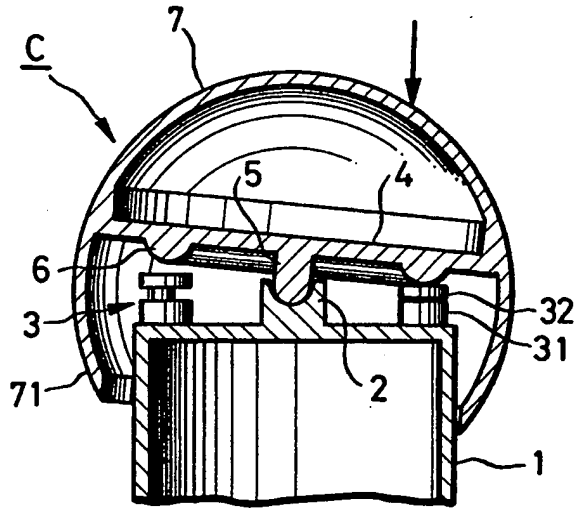

FIG. 1 c

